



IoT-BASED VOLTAGE CONTROL IN SMART GRID WITH FEED-FORWARD CONTROL IN AUTOMATIC VOLTAGE REGULATOR

KALIAPPAN SIVAKUMAR KRISHNA VENI¹, SARGUNAR THOMAS JAYA CHRISTA²,
JEYAPPAUL PRAVEEN PAUL³, JUANITA JOYCE⁴

Keywords: Smart grid; Voltage control; Internet of Things (IoT); Excitation current of a generator; Automatic voltage regulator; Shunt capacitor.

Implementing a smart grid integrates modern digital technologies, including monitoring systems, two-way communication capabilities, and automated control mechanisms, to enhance the grid's overall efficiency. Maintaining voltage within specified ranges is a crucial duty of a distribution network operator. The voltage of the smart grid depends on the generating source, type of electrical load, and distance of the transmission line. This paper introduces a novel method for real-time voltage regulation of a smart grid using Internet of Things (IoT) technology. This paper aims to enhance the voltage stability of the system by overseeing voltage levels at various nodes within a smart grid and choosing and operating the appropriate correction mechanism. The adjustment mechanisms to be done are dynamically varying the excitation current of generators in a thermal power station and dynamically operating the switched capacitor bank and reactor, which are geographically located in different locations, using IoT. Feed-forward control is proposed in the automatic voltage regulator (AVR) at the generator side for efficient voltage control in smart grids with reduced response time for issues. The stress on the distribution network operator can be decreased in maintaining grid voltage.

1. INTRODUCTION

A smart grid is an innovative power distribution system that leverages digital technology to manage electricity more efficiently and dependably than conventional grid systems [1]. A smart grid is an electric power network that can intelligently coordinate the operations of all its interconnected users, including generators, consumers, and those who serve both functions, to deliver sustainable, cost-effective, and secure electricity supplies. Leveraging the Internet of Things (IoT) can be crucial in developing smart grids, leading to significant energy savings. Smart grids enabled by IoT primarily focus on enhancing energy efficiency and managing energy consumption at the lowest possible cost.

Challenges in a smart grid are:

Power availability: we need to find suitable generators to ensure 100% uninterrupted power. Now, this has been achieved to some extent.

Quality of power: the available power should have the correct frequency, voltage, and form factor.

Affordable power: we need to generate, transmit, and distribute power at a cost affordable to all

Clean and sustainable power: our energy resources must not pollute the atmosphere, and we must also identify energy sources that will last forever.

This paper considers the second challenge: supplying quality power to consumers. One of the most critical responsibilities of competent grid operators is to keep the voltage levels for customers within specified ranges. The grid voltage can fluctuate with changes in the load, typically remaining high during light-load conditions and low during heavy-load conditions. The management of voltage is presently a critical concern in distribution systems. To maintain the system's voltage within acceptable parameters, supplementary equipment must boost the voltage when it falls below the threshold and reduce it when it surpasses the upper limit. The smart grid employs the subsequent techniques to regulate the voltage.

Capacitor banks have traditionally offered voltage reinforcement and rectified displacement power factors in distribution networks [2]. Shunt capacitors are typically placed in receiving end substations, distribution substations,

and switching substations. Shunt capacitors introduce reactive volt-amperes into the line.

The literature contains research on shunt capacitor voltage control. In response to variable renewable generation, load tap changing transformers and switched capacitors can be synchronized to improve system voltage [1]. Voltage profiles for different solar PV system penetration levels were examined. Article [2] introduced a new real-time voltage control algorithm for innovative distribution systems with switched capacitors to manage renewable generations. The proposed voltage regulation method does not require load and renewable generation forecast data.

Researchers study reactive power's effect on voltage control. Jiang and Smedley examined how solar inverters affect voltage and reactive power (Volt-VAR) control, voltage profile, and energy efficiency [3]. An open decision support system modeled a practical Southern California distribution system with two solar plants. Smart grid health monitoring presents many design challenges.

Recently, FACTS devices have become popular for voltage control. Article [4] described a smart grid operation and management structure with distributed generation, FACTS, voltage control, and stability control. An innovative hybrid series-parallel switched/modulated FACTS-based filter/compensation system for smart grids is proposed [5]. The proposed FACTS filter/compensation mechanism uses hybrid series and shunt-switched switched banks governed by a dynamic time-decoupled multi-regulator multi-loop error-driven inter-coupled PID controller with weighted adjustment. MATLAB/Simulink digital simulation results verify the low-cost pulse width Modulated technique's efficacy. In recent years, the IoT has empowered power grids. Energy optimization and ease of use are achieved by monitoring and controlling electronic devices with these technologies. IoT technologies can accelerate smart grid development and improve electricity delivery services by making them more resilient, appealing, adaptive, and communicative.

Article [6] reviewed smart grid IoT application requirements and proposed a comprehensive set of technologies and standards. The applications and factors driving Smart Grid development are also listed. IoT-

^{1,2,3,4} Mepco Schlenk Engineering College, Sivakasi, India.

E-mails: krishnaveni.ks@mepcoeng.ac.in, stchrista@mepcoeng.ac.in, jpraveen@mepcoeng.ac.in, juanitajoyce2001@gmail.com

controlled smart grids and location-based power theft detection are described in [7]. IoT for smart grid transformer health monitoring was studied in [8]. Researchers thoroughly reviewed IoT-based smart grid environments. Software solutions and challenges like connectivity, stability, communication, cost, information privacy, and security are covered [9]. An extensive IoT-enabled smart grid survey was conducted [10]. The survey covers smart grid architectures, applications, and prototypes using IoT. IoT-aided smart grid system challenges and research directions are also discussed.

IoT in smart grid generation, transmission, and distribution is covered in Article [11]. Wind and solar energy, thermal generation, and energy storage facilities are smart grid generation IoT applications. Transmission IoT deployment requires smart grid congestion management and system security. The article also discusses how IoT affects active distribution networks, smart cities, microgrids, smart buildings, and industry. Another article discusses smart grid IoT architectures, applications, challenges, and future work [12]. The authors propose an IoT platform architecture for power distribution communities using intelligent perception devices that combine the software and hardware of prosumer-integrated communities' operation monitoring and metering equipment [13].

Article [14] explained IoT's architecture and the key technologies applicable to smart grids, including communication ideas and framework for IoT-based transmission and distribution monitoring. A medium-voltage smart grid power monitoring and control system was presented [15]. Smart grid network protection uses voltage and current sensor data. See [16] for smart grid security improvements.

Smart grids can control voltage efficiently with feed-forward control. Article [17] proposed a different real-time frequency regulation method for reconfigurable microgrids. Sectionalizing and tie switches are coordinated with feed-forward control of synchronous and inverter-interfaced distributed generators. The proposed strategy for improving microgrid frequency regulation works across load demand scenarios. Under high-inductive grid impedance, voltage feed-forward affects grid-connected converter control [18]. It suggests an enhanced voltage feed-forward approach with a bandpass filter to improve converter stability against grid impedance fluctuations, especially under high-inductive conditions. Article [19] proposed a model predictive control-based voltage and frequency control scheme for inverter-based distributed generations (DGs) that stabilizes converter operation across a wide grid impedance range. DG system disturbances, such as currents injected into the point of standard coupling, are used as feed-forward signals. These signals improve the transient response of the DG control system for various switched loads and for switching and operating the DG in a microgrid not connected to the primary power grid.

An improved efficient power control strategy, based on fuzzy gain scheduling of the conventional proportional-integral controller, is proposed for voltage-frequency control in an inverter-based distributed generation unit [20]. Article [21] deals with the nonlinear control of a five-level packed U-Cell inverter in a grid-on photovoltaic system.

Article [22] introduces a real-time, sensor-driven online method for estimating voltage profiles and implementing

coordinated Volt/VAR control in smart grids with interconnected distributed generators. Article [23] provides experimental verification of a robust model-free control approach for voltage regulation in a microgrid, achieved by managing two photovoltaic inverters. Article [24] utilizes high-speed state estimation for real-time, unobservable distribution systems to develop a deep reinforcement learning-based control algorithm to regulate the voltage across the system.

From the literature, a voltage control system that is more advanced and efficient can now be implemented in a smart grid with the advent of IoT technology. Voltage control systems utilize real-time data from IoT-enabled devices to continuously monitor grid performance and adjust voltage levels to meet changing demand or supply conditions. IoT-driven smart grids can anticipate and respond to issues faster, saving energy and costs.

Based on the drawbacks in the above literature, such as the computational complexity of model predictive control [19], complexity in parameter tuning for nonlinear control [20,21], dependence on high-quality state estimation [24], feed-forward control is preferred here. By analyzing the literature on voltage control in smart grids, it is found that feed-forward control has not been employed in automatic voltage regulators (AVR). This paper proposes an innovative solution to control the voltage in a smart grid. AVRs and capacitors are combined to create a voltage control system that is efficient and effective in a smart grid. The system is designed to automatically adjust the generator's excitation current and the capacitors' output in response to changes in demand. In addition, feed-forward control is used in AVR at the generator side for effective voltage control in smart grids. This paper describes a novel method for real-time voltage control in a smart grid that surpasses conventional voltage control models by effectively managing reactive power and ensuring proper voltage levels. A prototype model has been developed to validate this.

The paper is structured in the following way. Section 2 describes the concept of feed-forward control in AVR. Section 3 provides the methodology adopted for the research. Section 4 presents the details of the hardware setup developed for the proposed work. Section 5 explains the remote monitoring of the smart grid using a web page. Section 6 presents the results and summarizes the key findings of the research. Section 7 presents the conclusions and future directions of research.

2. FEED-FORWARD CONTROL IN AVR

At the generator side, feed-forward control is proposed in AVR for voltage control in smart grids. Feed-forward control is a technique used to improve a control system's response by considering the effect of disturbances on the output [17]. In a feed-forward control system, the AVR measures the voltage level at the generator output and compares it to the desired set point. The AVR then adjusts the excitation current to the generator based on the difference between the measured voltage and the set point. In addition to the measured voltage, the feed-forward control system also considers the effect of disturbances on the voltage level. For example, suppose there is a sudden increase in load demand. In that case, the feed-forward control system can anticipate the effect of this disturbance on the voltage level and adjust the excitation

current accordingly. By considering the impact of disturbances on the voltage level, feed-forward control can improve the response time of the AVR and help maintain a stable voltage level in the grid. This can reduce the risk of equipment failure and improve the efficiency of the grid.

Feed-forward control offers several advantages over traditional feedback control systems. Feed-forward control provides faster and more accurate control responses by predicting and compensating for disturbances before they occur [18]. This helps to minimize the impact of disturbances on the system and improve overall performance. Feed-forward control helps to reduce steady-state errors in the system by anticipating and compensating for disturbances in advance. This helps to improve the accuracy of the control system and reduce the need for corrective action. Feed-forward control is more robust than feedback control systems in the presence of disturbances or measurement noise. Feed-forward control helps mitigate the impact of these disturbances on the system by anticipating and compensating for them in advance.

Feed-forward control is also less sensitive to model uncertainty than feedback control systems. This is because feed-forward control relies on real-time data to predict and compensate for disturbances rather than a mathematical model of the system. Feed-forward control improves the stability of a system by anticipating and compensating for disturbances before they cause instability. This helps to prevent oscillations or other unstable behavior in the system.

3. PROPOSED METHODOLOGY

The main objective of this paper is to control the voltage in a smart grid by monitoring the voltage at different nodes and by choosing and operating the appropriate correction mechanisms, which are geographically located in other locations, using IoT. Another objective is to monitor the system remotely using a web-based dashboard.

Reactive power production, demand advanced and efficient, and flow at all levels of the system are utilized to achieve voltage control. The AVR controls the field excitation of the generating units to ensure that the voltage level at the generator terminals is maintained according to the schedule [25]. Shunt capacitors, in conjunction with the AVR, help to regulate voltage at specific buses in the system. The adjustment mechanisms dynamically vary the excitation current in a thermal power station and operate the switched capacitor banks.

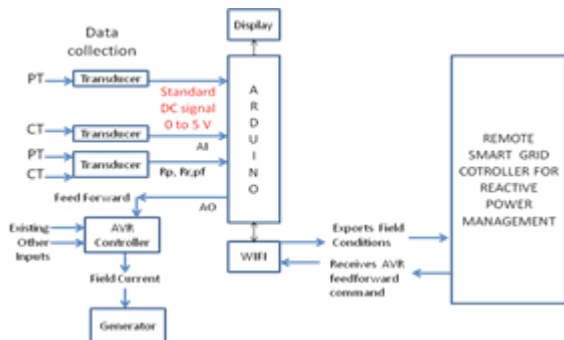

Fig. 1 – Block diagram of the proposed work on the generation side.

Figure 1 shows the block diagram of the proposed method on the generation side using feed-forward control. Generally, AVRs automatically regulate the voltage in a smart grid by

adjusting the generator's excitation current. They ensure that the voltage at various points in the grid remains within the allowable range, even when there are fluctuations in load demand or other factors that can affect voltage levels. In this proposed method, AVRs adjust the excitation current of the generator not only based on the generator's output voltage but also the feed-forward input, that is, the load voltages received from the cloud.

Figure 2 shows the block diagram of the proposed method at the load side. On the load side, the capacitors and reactors are switched ON or switched OFF based on the control signals received from the cloud.

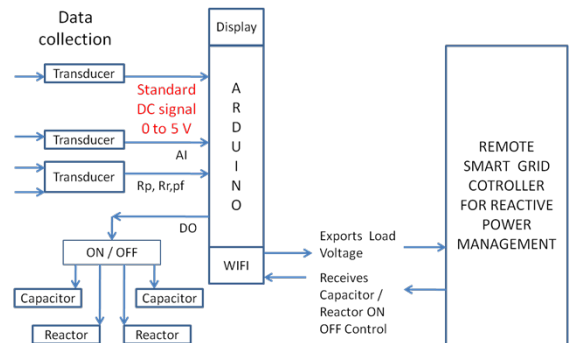

Fig. 2 – Block diagram of the proposed work at the load side.

Figure 3 shows the flowchart depicting the steps in deciding whether the correction should be applied. The following steps are involved in determining the correction to be used:

Data collection: The first step is to collect data from various sensors deployed in the grid, including voltage sensors, current sensors, and power sensors. This data could be collected in real-time and sent to the cloud for further analysis.

Data analysis: After collecting the data, analysis is required to detect any voltage fluctuations, imbalances, or other issues that need attention. Data analysis is done by comparing the values with the reference values.

Decision-making: After analyzing the data, the system must decide on the appropriate correction. This decision is based on pre-defined rules at the end of this Section.

Correction implementation: Once the decision is made, the system needs to implement the correction in the grid by adjusting the excitation current of the generator using AVRs, switching ON and switching OFF the capacitor banks.

Feedback loop: Finally, the system needs to monitor the grid after the correction is implemented and collect feedback data to evaluate the effectiveness of the correction.

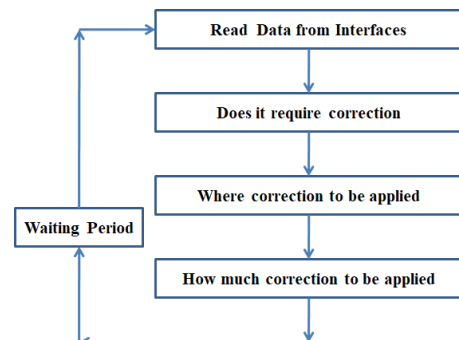

Fig. 3 – Flowchart depicting the steps in deciding the correction to be applied.

Figure 4 shows the Flowchart depicting the data to be read for the proposed system. Data will be collected from the generator, load, reactor, and capacitor banks to maintain voltage stability and ensure efficient power delivery. Figure 5 shows the parameters read from the generator, load end interfaces, reactor, and capacitor.

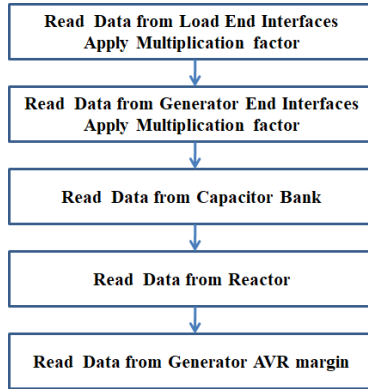

Fig. 4 – Flowchart showing the data to be read.

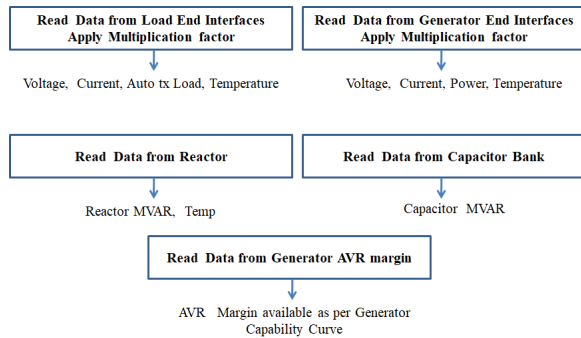

Fig. 5 – Data read from the generator, load end interfaces, reactor, and capacitor.

Voltage sensors measure the voltage levels at different points in the grid. This data is used to identify any voltage fluctuations, voltage imbalances, or voltage violations that need to be corrected. Current sensors measure the current levels at different points in the grid. This data calculates the power consumption and identifies any overloading issues that could impact the voltage levels. Power sensors are used to measure the power consumption at different points in the grid. This data identifies any power imbalances and calculates the reactive power required to maintain voltage stability. Temperature sensors are used to measure the temperature of various equipment in the grid. This data is used to identify any overheating issues that could affect the performance of the equipment. Load sensors could measure the load on transformers and other equipment in the grid. This data could be used to identify any overloading issues that could impact the voltage stability.

Before applying any correction, it is essential to check the voltage and current levels in the grid to ensure that they are within the allowable range. If the voltage or current levels are too high or too low, applying correction without stabilizing the voltage could be dangerous. It is essential to check for overloading on generators, transformers, and other equipment in the grid before applying correction. After applying correction, monitoring the grid for voltage, current, and power quality changes is crucial. Feedback data can be used to evaluate the correction's effectiveness and fine-tune

the voltage control system for better performance.

In this paper, Arduino is programmed to control the AVR and capacitor bank. When the generator voltage falls below 220 kV, the duty cycle of the PWM signal increases by 7 for every 1 kV decrease in value. When the voltage rises above 240 kV, the duty cycle of the PWM signal decreases by 5 for every 1 kV increase in value. When the load voltage falls below 220 kV, capacitor 1 turns ON. If it drops below 214 kV, capacitor 2 also turns ON. When the voltage rises above 218 kV, capacitor 2 turns OFF and when it rises above 224 kV, capacitor 1 also turns OFF.

4. HARDWARE SETUP

An experimental setup is crucial for deploying the IoT-based voltage control system in a real-world environment to test its effectiveness. In this project, a prototype is developed for checking the effectiveness of the proposed system. The hardware setup of the proposed work at the generation and load side is shown in Fig. 6 and Fig. 7.

In this IoT-based voltage control system, Arduino is used both on the generation and load sides. These controllers communicate with each other through the cloud platform, which acts as the central control system.

On the generation side, an LCD Display is interfaced with Arduino, which displays various smart grid parameters like voltage, power factor, and duty cycle of the PWM signal given to AVR for adjusting the excitation current of the generator and power at the generation side. The NodeMCU ESP8266 is interfaced with Arduino, which helps transfer this data from the Arduino to the cloud and receive it from the cloud.

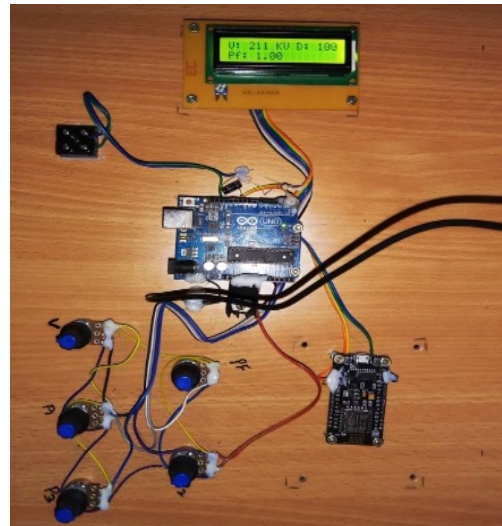

Fig. 6 – Hardware setup at the generation side.

The Arduino receives the load voltage through the cloud platform and provides a feed-forward signal to the AVR. The Arduino on the generator side is programmed to control the AVR. Based on the load voltage received, the duty cycle of the PWM signal of the Arduino is varied, and the analog output current supplied to the AVR changes. This causes a change in the current fed to the generator's field winding, and the generator voltage is adjusted to maintain the load voltage constant. The excitation current of the generator can also be measured.

On the load side, an LCD Display is also interfaced with Arduino, which displays various load parameters like

voltage, power factor, power, and the status of capacitors. The NodeMCU ESP8266 is interfaced with Arduino to transfer the load data from the Arduino to the cloud and receive data from the cloud. LEDs indicate the turn-ON and turn-OFF status of the two capacitors in the hardware setup. Arduino in the load side controls the capacitor bank.

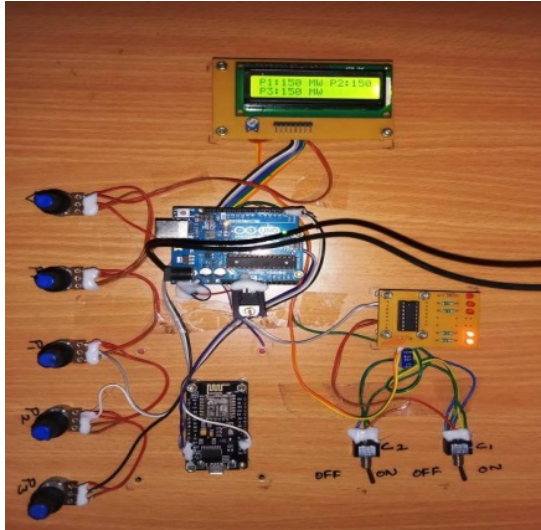

Fig. 7 – Hardware setup at the load side.

5. REMOTE MONITORING OF SMART GRID PARAMETERS

Remote monitoring of the smart grid is done using a web page. In this research, the front end of the webpage is created using HTML. The dynamic values of the parameters are collected from the database using PHP, and the back end of the webpage is done using it. Since the smart grid parameters are dynamic, the program is written so the webpage refreshes every 9 seconds. Database management is done using MySQL.

Remote monitoring of grid parameters in IoT-based voltage control in smart grid using a web page can be achieved by implementing the following steps:

Data acquisition: The first step is to acquire data from sensors installed at various points in the smart grid. The sensors measure different parameters such as voltage, current, power factor, and power.

Data transmission: The acquired data is transmitted to the cloud server using IoT communication protocols. The data can be sent to the server from the Arduino board.

Data storage: The data received from the sensors is stored in a database such as MySQL, which the web page can access.

6. RESULTS

The prototype is tested for various load voltages, and the status of the capacitors is noted and shown in Table 1. It is said that capacitors are switched ON based on the load voltage. Table 2 shows the variation of analog current given to AVR for various load voltages. As the load voltage decreases, the input current to AVR increases, increasing the generator's excitation current to increase the generated voltage. Feed-forward control reduces the need for manual interventions and improves response times to issues. It also minimizes overshoot/undershoot in voltage control. Table 3 compares performance with and without feed-forward control in terms of the time taken to achieve the reference

voltage, and it confirms the superiority of feed-forward control.

Table 1

Status of capacitors for various load voltages.

S. No	Load Voltage	Status of Capacitor C1	Status of Capacitor C2
1	230 kV	OFF	OFF
2	218 kV	ON	OFF
3	210 kV	ON	ON

Table 2

Variation in analog current supplied to AVR for various load voltages.

S. No	Load Voltage	Analog current
1	230 kV	4.5 mA
2	218 kV	5.6 mA
3	210 kV	6.4 mA

Table 3

Performance Comparison with and without feed-forward control.

S. No	Initial Load Voltage	Final Load Voltage	Time taken with Feed-forward control (secs)	Time taken without Feed-forward control (secs)
1	225 kV	230 kV	2.1	7
2	218 kV	230 kV	2.3	7.5
3	210 kV	230 kV	2.5	8.1

Figure 8 shows the webpage created to display the parameters from the cloud. The webpage displays the parameters for the generation side and load side. The voltage, real power, and power factor values at the different generating stations are displayed. The webpage also shows the PWM value used to measure the excitation current in the generator. The values of voltage, real power, and power factor are displayed for the load side. In addition, the ON/OFF status of capacitor banks is indicated.

There are several advantages to the proposed system. The feed-forward control implemented in AVR is an effective method of voltage control. This IoT-based voltage control system uses real-time data from sensors deployed in the grid to make informed decisions on voltage control.

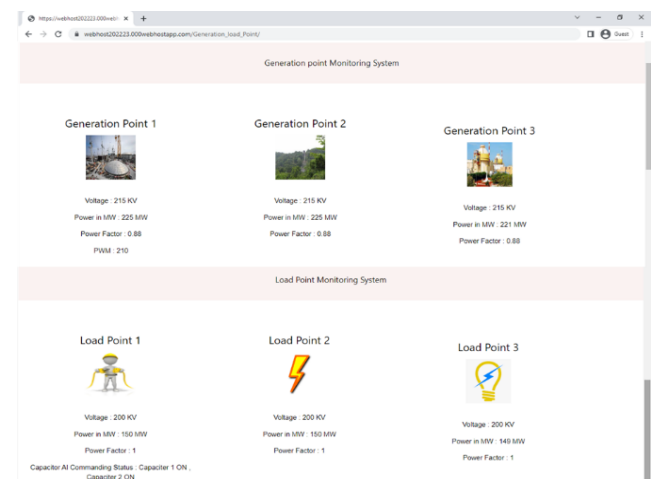

Fig. 8 – Webpage created to display the parameters from the cloud.

7. CONCLUSION

This research paper has discussed the framework for voltage control of smart grids using IOT, in which two controls, feed-forward control in AVR at the generator side and reactive power injection using capacitors and reactors on the load side, are included.

The novelty of this work is implementing an advanced control technique, which is feed-forward control in the AVR of the generator for effective voltage control in the smart grid. Data are sent from the controllers on the generator and load sides to the cloud, and the controllers also receive the measured data from the cloud. Corrective actions are taken based on the measured data. Since feed-forward control is used, the system responds quickly to changes in load voltage. Remote monitoring of grid parameters in IoT-based voltage control in smart grid is achieved through a web page.

The web page acts as a dashboard where users can view the real-time data of smart grid parameters. The IoT-based voltage control enhances smart power grids' operational flexibility and control capability. At the same time, feed-forward control offers significant advantages in an AVR but has inherent limitations. Implementing feed-forward control in an AVR increases system complexity. If the grid conditions change rapidly, the feed-forward control might lag in updating its predictions.

This can lead to inaccuracies in voltage regulation in highly dynamic environments. To mitigate this, adaptive algorithms or machine learning techniques can be used in the future.

CREDIT AUTHORSHIP CONTRIBUTION

Kaliappan Sivakumar Krishna Veni: presented idea.
Sargunar Thomas Jaya Christa: theory and computations
Jeyapaul Praveen Paul: results analysis
Juanita Joyce: simulations and results

Received on 3 April 2024

REFERENCES

- J.O. Petintin, M. Shaaban, *Voltage regulation in a smart distribution system incorporating variable renewable generation*, IEEE Innovative Smart Grid Technologies-Asia, pp. 583-588 (2014).
- O. Homace, A. Zakariazadeh, S. Jadid, *Real-time voltage control algorithm with switched capacitors in the smart distribution system in the presence of renewable generations*, International Journal of Electrical Power & Energy Systems, **54**, pp. 187-197 (2014).
- L. Jiang, K. Smedley, *Volt/VAR Control with DERs, LTCs, and Switched Capacitors: Case Study with a Commercial Distribution System*, IEEE Innovative Smart Grid Technologies-Asia, pp. 1330-1334 (2014).
- X.P. Zhang, *A framework for operation and control of smart grids with distributed generation*. Power and Energy Society General Meeting (2008).
- A.M. Sharaf, B. Khaki, *A FACTS-based switched capacitor compensation scheme for smart grid applications*, International Symposium on Innovations in Intelligent Systems and Applications, pp. 1-5 (2012).
- M. Kaur, S. Kalra, *A review on IOT based smart grid*, International Journal of Energy, Information and Communications, **7**, 3, pp. 11-22 (2016).
- S.S.N. Kumar, S.K. Rao, M.S. Raju, S. Trimurthulu, K. Sivaji, T.R.M. Reddy, *IoT-based control and monitoring of smart grid and power theft detection by locating area*. International Research Journal of Engineering and Technology, **4**, 7, pp. 1923-27 (2017).
- Y.W. Shahid, S. Sharma, *Internet of Things (IoT) based smart grid*, International Journal of Research, **7**, 11, pp. 2113-24 (2018).
- S. Mugunthan, T. Vijayakumar, *Review on IoT-based smart grid architecture implementations*, Journal of Electrical Engineering and Automation, **1**, 1, pp. 12-20 (2019).
- Y. Saleem, N. Crespi, M.H. Rehmani, R.L. Copeland, *Internet of Things-aided smart grid: technologies, architectures, applications, prototypes, and future research directions*, IEEE Access, **7**, pp. 62962-63003 (2019).
- H. Shahinzadeh, J. Moradi, G.B. Gharehpetian, H. Nafisi, M. Abedi, *IoT architecture for smart grids*, International Conference on Protection and Automation of Power System (IPAPS) (2019).
- A. Ghasempour, *Internet of Things in smart grid: architecture, applications, services, key technologies, and challenges*, Inventions, **4**, 1, 22 (2019).
- L. Tong, J. Zhou, J. Li, *IoT-based low-voltage power distribution system management and control platform*, Frontiers in Energy Research, **10** (2022).
- N.A. Hidayatullah, A.C. Kurniawan, A. Kalam, *Power transmission and distribution monitoring using Internet of Things (IoT) for smart grid*. IOP Conference Series: Materials Science and Engineering, **384** (2017).
- C. Babu, D.D. Kumar, K. Kumar, K.J. Reddy, *Power monitoring and control system for medium voltage smart grid using IoT*. IOP Conference Series, pp.120-127 (2020).
- J. Pandia Rajan, S. Edward Rajan, C.K. Aravind, A. Sivaprakash. *Smart grid security enhancement by detection and classification of non-technical losses employing deep learning algorithm*, International Transactions on Electrical Energy Systems, **30**, 9, pp. 1-12 (2020).
- J.Y. Park, J. Ban, Y.J. Kim, X. Lu, *Supplementary feedforward control of DGs in a reconfigurable microgrid for load restoration*, IEEE Transactions on Smart Grid, **12**, 6, pp. 4641-4654 (2021).
- S. Yang, X. Tong, J. Yin, H. Wang, Y. Deng, L. Liu, *BPF-based grid voltage feed-forward control of grid-connected converters for improving robust stability*. Journal of Power Electronics, **17**, 2, pp. 432-441 (2017).
- A. Saleh, D. Ali, I. Reza, *Model predictive control of distributed generations with feed-forward output currents*, IEEE Transactions on Smart Grid, **10**, 2, pp. 1488-1500 (2019).
- P. Kumar, Mohit K., N. Pal, *An efficient control approach of voltage and frequency regulation in an autonomous microgrid*, Rev. Roum. Sci. Techn. - Électrotechn. Et Énerg., **66**, 1, pp. 33-39 (2021).
- B. Hadmer, S. Drid, A. Kouzou, L. Chrifi-Alaoui, *Voltage sensorless control of five-level packed U-Cell inverter based on Lyapunov approach for grid-connected photovoltaic system*, Rev. Roum. Sci. Techn. - Électrotechn. Et Énerg., **69**, 2, pp. 135-140 (2024).
- P. Raghavendra, Nuvvula, S.S. Ramakrishna, Kumar, P. Polamarasetty, Gaonkar, N. Dattatraya., A. Sathoshakumar, Khan, Baseem, *Voltage profile analysis in smart grids using online estimation algorithm*, Journal of Electrical and Computer Engineering, pp. 1-9 (2022).
- R. Gupta, M. Paolone, *Experimental validation of model-less robust voltage control using measurement-based estimated voltage sensitivity coefficients*, IEEE Belgrade PowerTech, pp. 1-8 (2023).
- M. Golgol, A. Pal, *High-speed voltage control in active distribution systems with smart inverter coordination and deep reinforcement learning*, IEEE Power & Energy Society General Meeting, pp. 1-5 (2024).
- A. Soundarapandian, S. Muralidharan, *Enhancing the transient performances and stability of AVR system with BFOA tuned PID controller*, Journal of Control Engineering and Applied Informatics, **18**, 1, pp. 20-29 (2016).