



STUDY ON AUTOMATION PROGRAMMING TO MONITOR AND CONTROL A SCREW ELECTRO-COMPRESSOR

ANDREI MITRU¹, MIHAELA ROMAN², CORA COTESCU³

Keywords: Programming; Programmable logic controller (PLC); Operator panel; Automation cabinet; Screw electro-compressor; Logic diagram; Software state; Screen.

The article describes the programming architecture of a programmable logic controller (PLC) and an operator panel that is part of an automation cabinet of a screw electro-compressor. Behind the operation of a screw electro-compressor, there is a programming logic presented in the article that is implemented according to the requirements of each project. The article presents all the states of a screw compressor that are implemented in the PLC by a programmer in the form of software sequences. The article depicts the logic diagrams used to facilitate the software implementation process. Following the software implementation in the PLC of the logic diagrams, the article has a second software that contains a series of screens for the operator panel. The operator panel is a touch-screen type and communicates with the PLC through a defined communication protocol displaying the parameter values in real time on the programmed screens. The software developed for the operator panel by a programmer has the role of facilitating a human operator to monitor parameters and transmit commands to the screw electro-compressor. The article ends by presenting the conclusions that argue the efficiency and safety in operation through the presented software concept of a screw electro-compressor.

1. INTRODUCTION

A rotary-screw compressor, a vital gas compressor for large applications like refrigeration cycles and industrial compressed air systems, differs from traditional piston compressors. Twin-screw compressors consist of helicoid-lobed rotors in a casing, forming a volume-dependent working chamber. Rotor profiling algorithms define the machine volume, establishing meshing conditions for various rotor curves analytically or through discrete points.

The automation cabinet of a screw electro-compressor is made up of a metal construction protected against corrosion by electrostatic field painting. The enclosure is provided with a metal door with hinges and special locks. Inside the automation cabinet are a metallic panel, circuit breakers, a programmable logic controller (PLC), power sources, terminals, and relays. The automation cabinet has a link to the grounding terminal [1–3].

The automation cabinet of the compressor is intended to ensure for the plant:

- Supervision and display of the technological parameters of the compressor in all its operating regimes to ensure a maximum safety operation, including in the shutdown sequence;
- Operation under normal conditions and safety management during faulty situations;
- Driving electrical motors with variable speed through frequency converters considering the reference value of parameters;
- Testing sequences on the component sub-systems independently;
- The possibility of data acquisition and remote transmission.

The main function of the automation cabinet is to supervise the compressor status in all operating regimes, ensuring:

- Starting of the compressor;
- Operating of the compressor;
- Shutting down the compressor;
- The acquisition of the working and safety parameters by the PLC and their transmission to an operating panel for visualization and interpretation;
- Tracking the safety parameters during compressor operation and taking measures that prevent unwanted or irreversible events.
- Data acquisition and recording of parameter values into files stored inside an external device.

An optimal choice of compressor usage can significantly impact operating costs, and automated decision support for this task of compressor selection has often been tackled using the simulation approach [4]. Furthermore, depending on the customer's requirement for air dryness, an adsorption air dryer is installed after the heat exchanger [5].

Early rotor profiles suffered energy inefficiency due to substantial leakage areas. Innovations, notably Lysholm's and Schibbye's SRM-A profile, significantly reduced internal leakages relative to rotor throughput. Screw compressor development involves mathematical modeling, experimental validation, design, product development, training, and optimization. Analytical and numerical methods, including computational fluid dynamics, have been used for performance analysis. Growing emphasis on CFD enhances accuracy, while simplified analytical modeling allows easy assessment of design and operational parameters [6–8].

2. LITERATURE REVIEW

The last ten years have witnessed the emergence of Industry 4.0, also known as the Fourth Industrial Revolution, characterized by automation and the Internet of Everything, including people, services, data, and things. This transformation has greatly impacted education, which has given rise to Education 4.0. It has made it possible for several

¹ INCD Turbomotoare COMOTI, Bv. Iuliu Maniu 220D, Bucharest, Romania
E-mail: andrei.mitru@comoti.ro, mihaela.roman@comoti.ro, cora.cotescu@comoti.ro

creative substitutes for conventional information transmission techniques [9].

Gas compression is achieved via a rotary screw compressor with the use of two helically grooved rotors, one for each gender. From the entrance to the output, the spacing between these rotors is designed to gradually get smaller from the inlet to the outlet [10].

The screw compressor is a positive displacement rotary machine. It consists of meshing helical lobed rotors rotating within a fixed casing enclosing them. Screw compressors are, therefore, efficient, compact, simple, and reliable. Screw compressors can be either single or multistage machines [11].

The dry screw compressor, developed in the late 1940s and widely adopted in the 1960s for plant air services, is joined by the single-screw compressor introduced by Zimmern in the 1950s. In today's era of escalating carbon emissions and environmental challenges, improving energy efficiency is crucial for mitigating these issues [12–14].

Screw compressors offer a weight reduction of up to fivefold and a service life nearly ten times longer than reciprocating compressors of similar capacity. The annual global production of positive displacement compressors surpasses 200 million units, consuming approximately 17% of the world's electric power output in various industrial, commercial, and domestic applications [15].

With advantages in manufacturability, involute contact, and design simplicity, the rack generation principle was improved incrementally in later profiles like Stosic, Cavatorta, and Tomei. Fu Sheng's, Gardner Denver's, City's, and Kaeser's rotor profile patents from the past two decades showcase state-of-the-art features, highlighting the N-rack similarity. Kaeser's profile uniquely employs the rotor generation principle, largely based on its predecessor, the SIGMA profile by Bammert. This screw compressor provides air for equipment and instrumentation, contributing to processes like nitrogen gas production, dry gas seals, and mixed refrigeration systems in industrial settings [16].

For a distinctive approach, another paper aimed to tune the structure reverberation to coordinate the vibration source with the assistance of a mechanical screw compressor accessible on a testing bench. The vibrations were measured concerning the spectral components' recurrence, amplitude, and solidness. The focused-on frequency is found at ~83 Hz and is produced by the male rotor of the twin-screw compressor running at the ordinary quasi-static speed of 2 500 rpm [17].

The SMARTRONIC compressor operates via two distinct circuits: the first handles intake, compression, separation, and drying of the working air, while the second focuses on oil circulation. The air is filtered to eliminate large particles and dust that may harm internal components. Subsequently, it passes through an intake valve and is further cooled and compressed to the desired pressure with an additional oil supply [5].

Svenska Rotor Maskinen (SRM) leads in screw compressor design, while major manufacturers include Compair (U.K), Atlas-Copco (Belgium), Ingersoll-Rand, Denver Gardner (USA), and GHH (Germany). Leaders in refrigeration and air conditioning are York, Trane, and Carrier (USA), with notable Japanese manufacturers like

Hitachi, Mycom, and Kobe-Steel. Industry reshaping through mergers is evident, and Holroyd (U.K) is the world's largest screw rotor manufacturer. Key contributions to screw compressor theory are acknowledged by Amosov et al. (1977), Rinder (1979), Konka (1988), O'Neil (1993), Arbon (1994), and Xing (2000). English publications, including O'Neil (1993) and Arbon (1994), complement Xing's comprehensive Chinese textbook from 2000 [7].

3. METHODOLOGY

For the PLC, in terms of programming, the proposed approach has only programming in the Ladder diagram language as its core. Therefore, any programmer who knows this programming language can implement the entire algorithm that will be the basis of the monitoring and control of a screw electro-compressor.

Unlike other approaches in the same field that involve using several programmers and several programming languages with scripts to develop PLC software, the novelty of this solution is applying a single programming language to develop a solution for the automation of an electro-screw compressor. Thus, such an approach simplifies the programming process and subsequent automation cabinet maintenance achievement from a software point of view, which will require only one programmer.

Also, this solution is easy to apply to PLC equipment from any supplier that supports implementation through the Ladder diagram programming language. Thus, the solution is adaptable to the situation in which it must be integrated with various equipment from a specific supplier already existing in the project theme.

The solution's originality lies in organizing operating sequences for each compressor state. Each state corresponds to an address that determines a unique operating sequence, which executes itself by excluding the other sequences and triggers a set of implemented instructions.

The automation cabinet is based on a monitoring and control system. Therefore, a programmable logic controller (PLC), Emerson Versamax or Alen Bradley, interfaces with the transducers on the compressor skid through specific adapters. The PLC will interface with the execution elements from the compressor through relays, contactors, and adapters.

The configuration of the PLC monitoring and control system will contain:

- A power source;
- A central processing unit with serial communication possibilities (1 × RS232; 1 × RS485) and Ethernet, where complex software will be stored. The PLC software will allow to establish how the compressor operates, ensuring full and accurate control of all the skid devices;
- Modules with analog inputs, current 0–20 mA or 4–20 mA, that take the information from the skid transducers;
- Modules with analog outputs, current 4–20 mA, through which commands are given to the skid execution elements with fine adjustment;
- Modules with digital inputs, 0–24 Vcc that signal different states of the various components of the skid;

- Modules with digital outputs, 0-24 Vcc, will give the skid execution elements active/inactive commands.

Once powered up, the programmable logic controller enters a state called Init. In this state, the PLC software sequences either close or switch off all the devices from the compressor skid, such as valves, electric motors, and electrical resistance.

As the operator pushes the virtual start button on the operating panel, the compressor's state changes from init to operating. Once in the operating state, the PLC executes all sequences required for the compressor to function.

There are three compressor shut-down types: pressurized stop, emergency stop, and power fault stop. each type of shut-down has a defined state in the PLC software.

Inside the PLC software, the compressor's state changes automatically from Operating to Pressurized Stop when a developed failure condition is achieved. The compressor state changes to emergency stop if an emergency button is pressed. If a major power failure occurs, the compressor state changes to a power fault.

Considering the PLC software, the compressor returns to the Init state after two minutes have passed into any shutdown state.

The PLC automatically commands a pressurized stop if the compression gas pressure is low. The compressor enters the Standby state, as seen in Fig. 1. From this state, the PLC software changes automatically from Stand By to operating if the gas pressure increases and reaches a minimum set value, or it changes from Standby to Init if a critical event occurs.

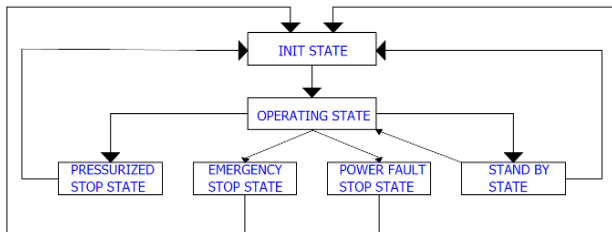

Fig. 1 - Programmable logic controller software states of a screw compressor.

3.1. INIT STATE PROGRAMMING

During the PLC Init state presented in Fig. 2, the PLC software closes all-electric valves such as admission valve SDV1, oil valve SDV2, discharge valve SDV3, drain valve BDV2, recirculation valve BDV4, chimney valve BDV5, and stop oil flow valve SV1. The operator cannot start the compressor if one or more valves cannot close.

There are three frequency converters: one for the main motor, one for the oil cooling, and one for the gas cooling. These three frequency converters must send a ready signal to the PLC; otherwise, the operator cannot start the compressor.

Two emergency buttons on the automation cabinet and the skid must not be pushed; otherwise, the chimney valve will open, and the operator cannot start the compressor.

If the minimum oil level condition is not fulfilled, a warning message will appear on the alarm's dedicated screen, and the operator cannot start the compressor.

All the skid compressor sensors, such as pressures, temperatures, and vibrations, must operate optimally. One

faulty sensor will warn, and the compressor cannot be launched into operation.

Oil heating is performed during the Init state when the oil separator temperature (Tuvs) is below 20 °C. The compressor can be launched in operation only if the oil separator temperature (Tuvs) is above 20 °C.

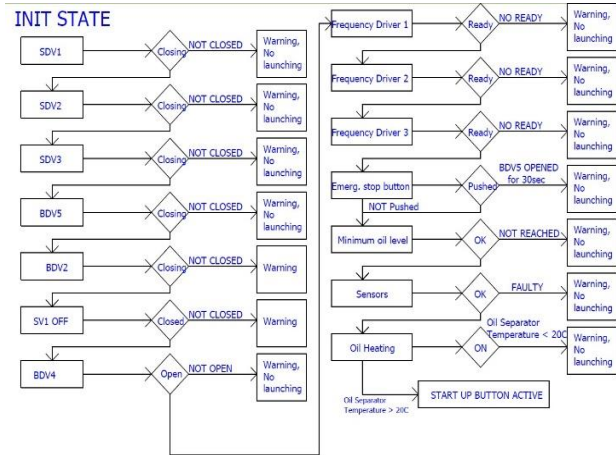

Fig. 2 – Init state logic diagram for PLC software.

3.2. OPERATING STATE PROGRAMMING

Once in the Operating state sequence, admission valve SDV1, discharge valve SDV3, and oil stop flow valve SV1 are opened by PLC software, while recirculation valve BDV4 is closed. Oil valve SDV2 will open progressively and allow the oil to be cooled as the oil temperature exceeds 45°C. Chimney valve BDV5 will open at the beginning for 15 seconds only if low gas pressure is present. The pressurized shutdown of the compressor is activated if one or more than one of these valves cannot operate, except drain valve BDV2, which always gives only a warning message if it's stuck or there is a condensed water issue. The logic diagram of the Operating state is presented in Fig. 3.

The main frequency converter must transmit a run signal to the PLC, while the oil cooling and gas cooling frequency converters will enter a running state when the oil and gas temperatures reach 45 °C. The compressor's power fault stop is engaged if the main frequency converter transmits a fault signal to the PLC. If any of the oil and gas frequency converters sends a Fault signal to the PLC, a pressurized stop of the compressor is engaged.

At the beginning of the process, an oil pump lubricates the compressor. After the lubrication, the oil pump turns off automatically during the Operating state.

The emergency buttons are required not to be pressed during the operating state; otherwise, the emergency stop will be engaged. The compressor's pressurized stop is automatically activated when the minimum oil level is below the limit.

The compressor sensors have to be valid. One faulty sensor will trigger the compressor's pressurization. Inside the operating state software sequence are set value limits for each parameter, such as temperature limits, pressure limits, speed limits, current limits, and vibration limits, that can trigger an automatic pressurized stop when exceeded.

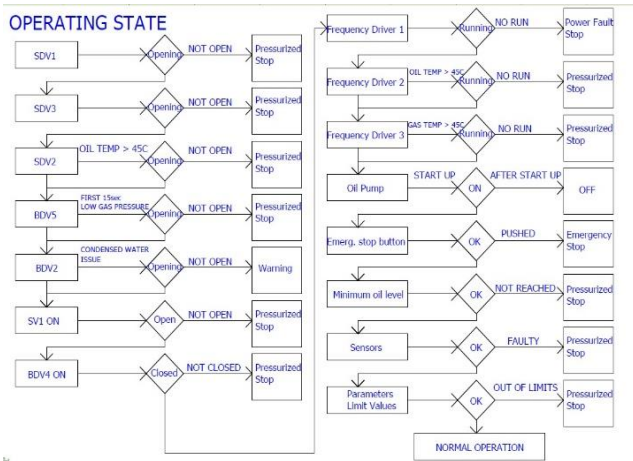

Fig. 3 – Operating state logic diagram for PLC software.

3.3. PRESSURIZED STOP STATE AND POWER FAULT STOP STATE PROGRAMMING

From the Operating state, the software can switch to the Pressurized stop state. The transition can be voluntary when the operator presses a virtual button or automatic when a programmed failure condition is met.

The pressurized shutdown sequence lasts 245 seconds. At the beginning of this sequence, the recirculation valve BDV4 is opened to equalize the pressure between the discharge and the compressor inlet, and the rest of the valves receive the closing command. Stop oil flow valve SV1 receives the closing command 6 seconds after entering the pressurized stop state.

Also, upon entering the pressurized shutdown sequence, the frequency converter reduces the main engine speed on a 10-second slope, at the end of which the zero value of the main engine speed is reached.

The motors of the gas and oil coolers are shut down by the related converters through this sequence. The electric power supply to the oil pump motor is cut off, and when the 245 seconds are exceeded, the PLC software of the screw compressor goes from the Pressurized stop state to the Init state, as seen in Fig. 4.

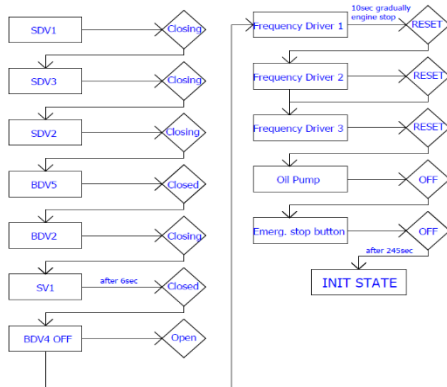

Fig. 4 – Pressurized stop state logic diagram for PLC software.

The power fault stop state is almost identical to the Pressurized stop state. It can only switch from the operating state if the main frequency converter sends a fault signal to the PLC. The 10-second shutting-down slope of the main motor is missing during the Power fault stop state. Only a reset command is sent from the PLC software to the main frequency converter, which stops the main motor.

3.4. EMERGENCY STOP STATE PROGRAMMING

The Emergency stop state illustrated in Fig. 5 can only be switched from the operating state. The switch can be performed voluntarily by pressing one of the emergency buttons or automatically when the gas detector signals the presence of gas in the automation cabinet room.

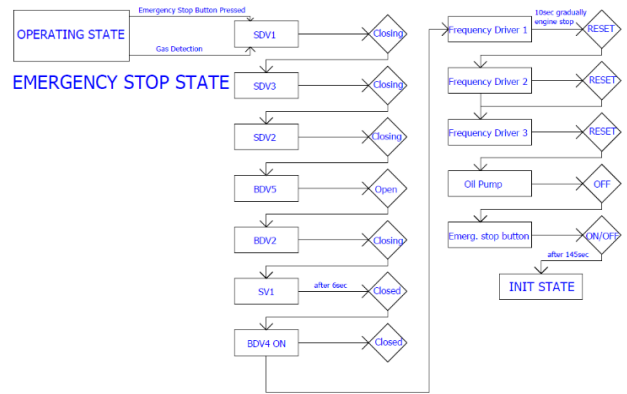

Fig. 5 – Emergency stop state logic diagram for PLC software.

The pressurized shut-down sequence lasts 145 seconds. The valve sequence is like the one in the Pressurized stop state, except for the recirculation valve, which remains closed, and the chimney valve BDV5, which opens to evacuate the gas to the chimney.

The rest of the sequence is identical to the one in the Pressurized stop state. At the end of the 145 seconds, the PLC software of the screw compressor switches from the emergency stop state to the init state.

3.5. STAND BY STATE PROGRAMMING

The software can automatically switch to the standby state from the operating state when the gas pressure at the compressor inlet is below a certain set limit.

Thus, the PLC automatically shuts down the compressor. The valves, frequency converters, and oil pump sequences are identical to those in the pressurized stop state.

Like in the Init state, the oil is heated in the Stand-by state when its temperature drops below 20 °C.

If the oil temperature exceeds 20 °C and gas pressure exceeds a certain set limit, the compressor will automatically return to the operating state.

In the standby state present in Fig. 6, if a fault condition defined in the PLC software is reached or if the operator no longer wants the automatic start of the compressor and activates the virtual stop button on the operator panel, the software will switch the standby state to the Init state.

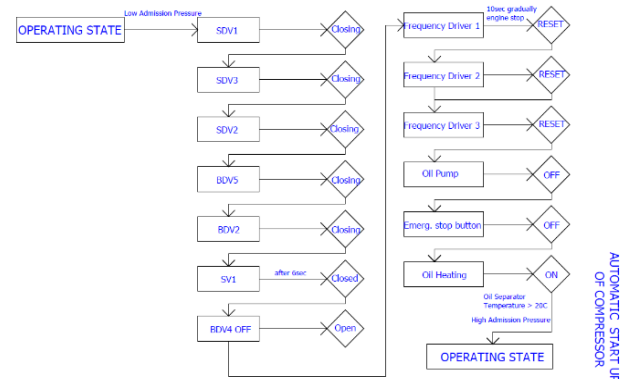

Fig. 6 – Stand-by state logic diagram for PLC software.

4. RESULTS AND DISCUSSION

The automation cabinet door has an operating panel with a human-machine interface (HMI). On this panel, an operator can view the installation status, warnings, alarms, etc., and give the compressor commands.

The technological diagram screen is the first screen to appear on the operating panel after the automation cabinet is supplied with electrical energy. It shows parameters optically signalized by different colors (green, yellow, red).

Figure 7 shows the compressor's technological diagram, which presents the main engine, the compressor, the oil circuit, the gas circuit, all transducer elements, and the input/output isolation valves.

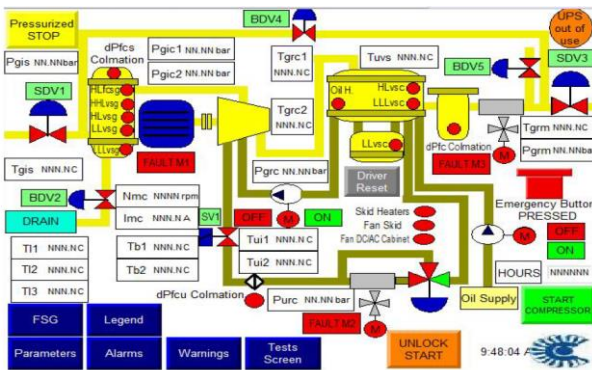

Fig. 7 – Programming design of the technological diagram screen for a screw electro-compressor.

On the HMI technological diagram screen, there are virtual buttons with the following functions:

- “UNLOCK START” is a button that appears when the compressor is waiting to be manually started. When this button is pressed, it will unlock the start button of the compressor only if all start-up conditions are fulfilled;
- “START COMPRESSOR” is a button that appears only after the unlock has been performed. When pressed, it launches the preparation steps for the compressor start-up and finally enters the operating state. The start-up will be canceled automatically by the PLC software if one of the parameters from the start-up conditions does not fall within the accepted technological limits.
- “STOP COMPRESSOR” is a button that appears only in the operating state. When pressed, it will command the compressor to shut down.

There are also buttons on the technological diagram screen that, when pressed, trigger other screens to appear.

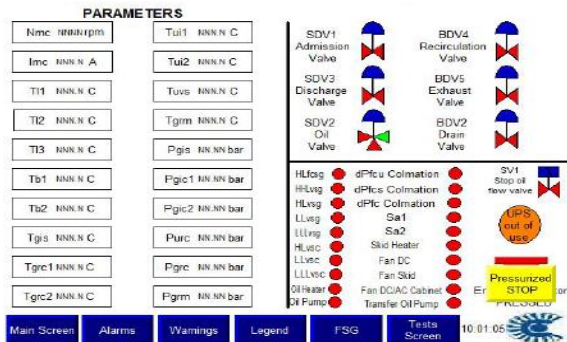

Fig. 8 – Programming design of the parameter screen for a screw electro-compressor.

When pressed, the parameters button will launch the visualization screen of the values and statuses for all the

analogical and digital compressor parameters, divided into categories. The design of the parameter screen for the screw electro-compressor is presented in Fig. 8.

Solenoid valves (SDVs, BDVs) can turn red for the close position, green for the open position, and blue for the in-progress position. For technological parameters such as pressures, temperatures, and digital signals, red means a failure, yellow means a warning, green means a parameter in operation, and grey means a parameter not in operation.

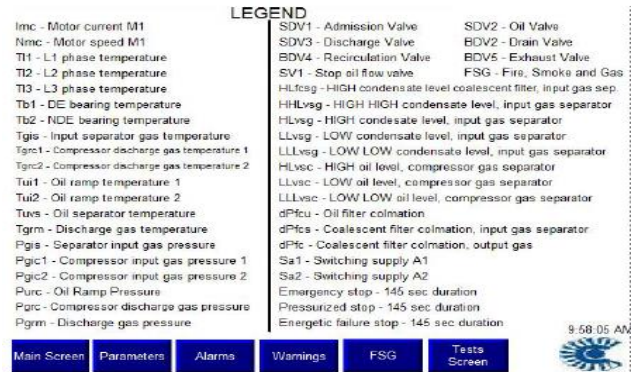

Fig. 9 - Programming design of the legend screen for a screw electro-compressor.

When pressed, the legend button launches the screen with the explicit abbreviations of the compressor parameters used in the technological and parameters screens. The legend screen is illustrated in Fig. 9.

For any compressor operation sequence, the PLC permanently monitors the values of the technological parameters, signaling optically and acoustically any change from the technologically imposed values.

There are warning messages for the parameters whose values do not allow the compressor to start up. The compressor cannot be started until the conditions in the messages are fulfilled.

Certain events during the compressor's operating state will trigger non-critical messages and warn the human operator. In case of failures, all safety protections for the compressor to perform automatic shutdown are transmitted to the PLC central processing unit, and the human operator will be notified through a message about the failure and its causes.

The Alarms button, when pressed, launches the screen with the alarm table (Fig. 10), which informs the operator about compressor start issues or shut-down causes. The operator will know the exact time and cause when the PLC software has performed any type of shut-down.

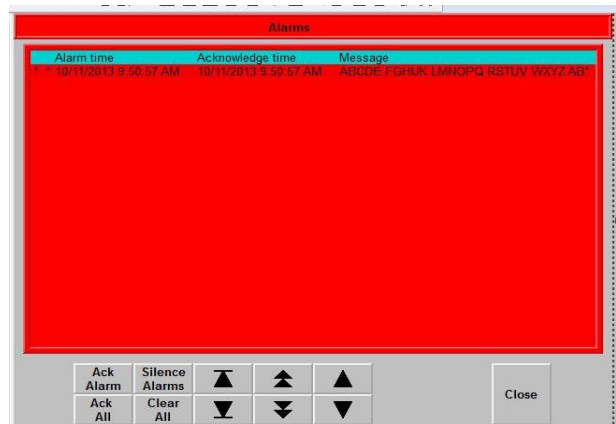

Fig. 10 – Programming design of the compressor alarm screen.

When pressed, the test button launches the test screen (Fig. 11), which allows the individual command of the compressor devices. This screen can only be accessed when the compressor is in the Init state. The operator can test individually any pump, motor, or electrical valve of the compressor to verify their condition and operation result.

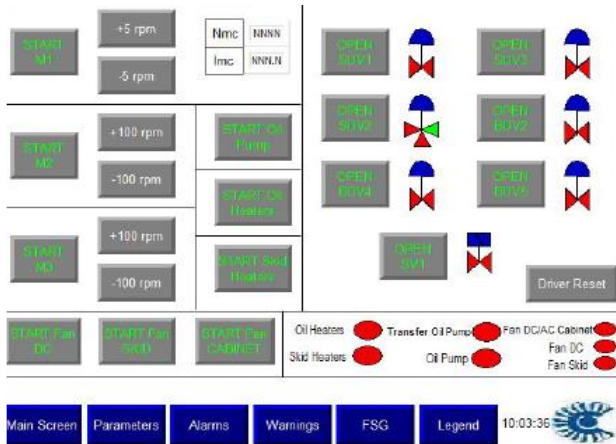

Fig. 11 – Programming design of the compressor test screen.

5. CONCLUSIONS

Through everything presented, the software architecture that defines the driving process of a screw electro-compressor emerges in the article.

The PLC software is developed in ladder diagram language and consists of the init state, operating state, pressurized state, emergency stop state, power fault state, and standby state software sequences.

In addition to these sequences, a Fault sequence is developed in the PLC in which all compressor shutdown conditions are programmed, a Warning sequence in which all compressor warning conditions are programmed, a Comparison sequence in which the thresholds for each parameter are set, a Scaling sequence in which parameters are scaled and a sequence of Instrumentation lines in which the fault conditions for each line are established.

The screens developed and presented in the article ensure the interface of the human operator with all the equipment of the screw electro-compressor, ensuring its monitoring by displaying the technological scheme with all parameters, displaying the warning and fault messages, and grouping the parameters according to categories such as the circuit of gas, the main engine, and the oil circuit.

The article describes developing PLC and operator panel software for an automation cabinet to monitor and control an electro-compressor.

For more than ten years, such electro-compressors have been operating in various regions of Romania, and using the

presented automation software architecture has proved highly efficient and safe.

Received on 14 March 2024

REFERENCES

1. D. Valand, K.K. Bhabhor, D.B. Jani, N.Mr.T. Gandhi, *Parametric analysis of a screw compressor: a critical review*, pp. 59–71, (2023).
2. N. Stosic, *On gearing of helical screw compressor rotors*, Proceedings of the Institution of Mechanical Engineers, Part C: Journal of Mechanical Engineering Science, 1998.
3. N. Stosic, I.K. Smith, A. Kovacevic, E. Mujic, *Geometry of screw compressor rotors and their tools*, Journal of Zhejiang University–Science A, **12**, 4, pp. 310–326 (2011).
4. H.H. Nguyen, V. Uraikul, C.W. Chan, P. Tontiwachwuthikul, *A comparison of automation techniques for optimization of compressor scheduling*, Advances in Engineering Software, **39**, 3, pp. 178–188 (2008).
5. J. Pospíchal, M. Volf, *The analysis of oil circuit cooling of a screw compressor*, MATEC web of conferences, **383**, pp. 00018–00018 (2023).
6. S. Patil, M. Davis, N. Stosic, A. Kovacevic, N. Asati, *Contribution of modern rotor profiles to energy efficiency of screw compressors*, IOP Conference Series: Materials Science and Engineering, **1267**, 1, p. 012006 (2022).
7. N. Stosic, I.K. Smith, A. Kovacevic, *Opportunities for innovation with screw compressors*, **217**, 3, pp. 157–170 (2003).
8. J.G. Persson, *Design parameter study to extend the capacity range of dry twin screw compressors*, IOP Conference Series: Materials Science and Engineering, **1267**, 1, pp. 012009–012009 (2022).
9. I.C. Mustață, L. Bacali, M. Bucur, R.M. Ciuceanu, A. Ioanid, A. Ștefan, *The evolution of Industry 4.0 and its potential impact on industrial engineering and management education*, Rev. Roum. Sci. Techn. – Électrotechn. et Énerg., **67**, 1, pp. 73–78 (2022).
10. C. Săvescu, V. Petrescu, D. Comeagă, I. Vlăducă, C. Nechifor, and F. Niculescu, *Vibration Analysis of a Twin-Screw Compressor as a Potential Source for Piezoelectric Energy Harvesting*, Rev. Roum. Sci. Techn. – Électrotechn. et Énerg., **68**, 3, pp. 253–258 (2023).
11. N. Stosic, I. K. Smith, and A. Kovacevic, *Optimisation of screw compressors*, Applied Thermal Engineering, **23**, 10, pp. 1177–1195 (2003).
12. W.E. Bill Forsthoffer, *Screw compressors*, Elsevier eBooks, 2005, pp. 371–392.
13. C. Nechifor, V. Năvrăpescu, S. Tomescu, C. Săvescu, M. Roman, R. Conțiu, A. Stoicescu, *Optimizing the Electronic Control of Suction Valves for Gas Compression Units*, Rev. Roum. Sci. Techn. – Électrotechn. et Énerg., **68**, 2, pp. 182–187 (2023).
14. S.Y. Wang, Z.L. Wang, H. Shi, Z.M. Wang, M. Hao, J. Wang, *Study on screw rotor thermal machining method of single screw compressor*, IOP Conference Series: Materials Science and Engineering, **1180**, 1, pp. 012011–012011 (2021).
15. N. Stosic, *On heat transfer in screw compressors*, International Journal of Heat and Fluid Flow, **51**, pp. 285–297 (2015).
16. S. Patil, M. Davis, N. Stosic, A. Kovacevic, N. Asati, *Contribution of modern rotor profiles to energy efficiency of screw compressors*, IOP Conference Series: Materials Science and Engineering, **1267**, 1, p. 012006 (2022).
17. C. Săvescu, D. Comeagă, A.M. Morega, Y. Veli, *Experimental Tests with Piezoelectric Harvester for Tuning Resonant Frequency to Vibrating Source*, Rev. Roum. Sci. Techn. – Électrotechn. et Énerg., **67**, 4, pp. 457–460 (2022).