

# POWER FLOW BALANCE – SIMULATIONS AND EXPERIMENTS IN ELECTRICAL NETWORKS

IONUT-MARIUS MINDREANU<sup>1</sup>, RADU-MIRCEA CIUCEANU<sup>2,\*</sup>, IOSIF-VASILE NEMOIANU<sup>2</sup>

**Keywords:** Distribution grid; Active power; Reactive power; Unbalanced consumers; Nonlinear consumers; Symmetrical components power theory (SCPT); Powers of symmetry; Powers of non-symmetry; Residual (distorting) powers; Harmonics; Numerical simulation.

This paper provides a detailed analysis of the effects of electric power transfer in distorted and asymmetric regimes specific to three-phase, four-wire systems by analyzing and exposing the negative influence of nonlinear and unbalanced consumers on the other grid-connected consumers and the power line. A key aspect of this study is to investigate the impact of these regimes on the parasitic active and reactive powers, which affect linear and balanced consumers due to distorted and unbalanced loads. The quantitative evaluation of the phenomena involved is carried out through the symmetric component power theory (SCPT), introduced by Acad. Andrei Țugulea, allowing the identification of the source of the non-symmetry and residual powers. This approach is consistent with the experimental data acquired in our previous research, proving the validity of SCPT. Circuit simulation was done with SPICE software, confirming the consistency between the data acquired experimentally and those provided by the numerical simulation.

## 1. INTRODUCTION

To demonstrate the Țugulea's powers theory applied to grid models in a circuit with unbalanced electrical charges and nonlinear elements [3,14–17], numerical simulations are performed in addition to the practical experiments carried out in [1,2]. These simulations focus exclusively on the experimental electrical circuits with neutral conductors under scrutiny in [2], using a professional electrical circuit analysis environment and dedicated software for power calculations. This process aims to verify and validate the experimental results obtained in the laboratory through a complementary approach based on computer simulations.

SPICE (analog and mixed-signal simulation software) enables accurate analysis of circuit transient, harmonic, and stability phenomena, providing a complex environment for testing component performance under different conditions.

Unbalanced and distorted consumers pose a significant challenge in maintaining energy efficiency and grid stability, directly impacting the performance and sustainability of energy infrastructure [4–7]. Their presence in distribution systems leads to harmonic distortions and phase imbalances – phenomena that reduce efficiency, increase investments, and contribute to the overload of power grids, increased power losses, and degradation of electrical equipment [8–10].

Harmonic distortions arise due to nonlinear consumers such as power electronic devices, switching power supplies, variable-speed motors, and semiconductor-based equipment [11]. These distortions deform the voltage and current waveforms, affecting power quality and increasing losses in transformers and power lines. Additionally, harmonics can induce resonance in the network, generating dangerous overvoltages that may damage the used equipment [12–14].

On the other hand, phase imbalances occur when the load is unevenly distributed between the phases of a polyphase system, causing additional currents and voltage fluctuations that can affect the stability and operation of sensitive consumers. These imbalances are frequently encountered in networks supplying asymmetrically connected single-phase

consumers or industrial equipment with unbalanced loads [15–17].

The combined impact of harmonic distortions and phase imbalances can have significant consequences on the reliability and operating costs of the electrical system. Identifying and characterizing these phenomena is essential for developing adequate compensation and correction strategies to optimize power quality and minimize the negative impact on distribution networks [17–22].

## 2. ANALYZED EXPERIMENTAL CIRCUITS

For simulation and validation, a three-phase electrical circuit is proposed (Fig. 1), whose parameters correspond to the experimental circuit designed to study and analyze the distribution of active and reactive symmetry, non-symmetry, and residual powers, according to the acad. Țugulea's theory. In [1,2], the power circulations in different operating conditions and their impact on the power flow within the electricity grid are identified and calculated.

SPICE software simulation was used for the numerical simulation.

Figure 1 shows the configuration of the circuit to be analyzed. We have a three-phase electric generator that provides a symmetrical voltage system of direct succession, a balanced three-phase power supply line (the parameters of the generator are included in those of the power line), and two three-phase electrical loads connected to it, as follows: the first, presenting a distorting (nonlinear) and unbalanced nature, and the second, being linear and balanced. The distortions are generated by two nonlinear elements labeled EN<sub>1</sub> and EN<sub>2</sub> (two voltage converters whose schematic is shown in Fig. 2), placed on the first and second phases of the first electric load.

This structure enables the investigation of the impact of nonlinearities on currents and voltages within the network, facilitating a deeper understanding of their associated effects on the system's energy balance. To perform a detailed simulation and numerical analysis, it is necessary to convert the experimental circuit into a digital format, allowing their use in a simulation environment.

<sup>1</sup> Doctoral School of Electrical Engineering, National University of Science and Technology POLITEHNICA Bucharest, 313 Splaiul Independenței, 060042 Bucharest, Romania.

<sup>2</sup> Faculty of Electrical Engineering, National University of Science and Technology POLITEHNICA Bucharest, 313 Splaiul Independenței, 060042 Bucharest, Romania.

E-mails: ionut.mindreanu@stud.electro.upb.ro, radu.ciuceanu@upb.ro, iosif.nemoianu@upb.ro. (correspondence) radu.ciuceanu@upb.ro.

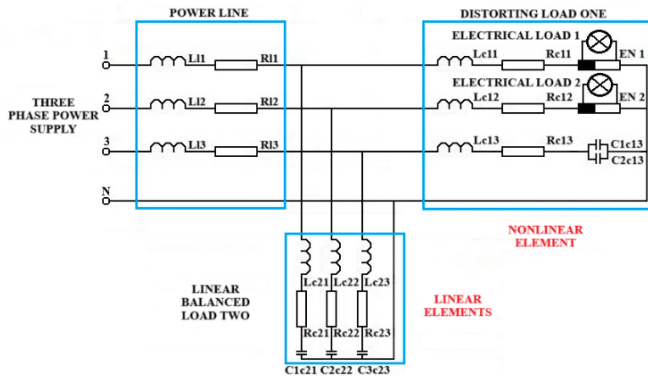

Fig. 1 – Detailed description of the experimental electrical circuit.

Table 1

Component element parameters (experimental circuit).

Electrical line	Distorting load one	Linear balanced load two
$L_{11} = 2.1$ [mH]	$L_{c11} = 15.8$ [mH]	$L_{e21} = 15.4$ [mH]
$L_{12} = 2.1$ [mH]	$L_{c12} = 15.3$ [mH]	$L_{e22} = 15.3$ [mH]
$L_{13} = 2.1$ [mH]	$L_{c13} = 15$ [mH]	$L_{e23} = 15.3$ [mH]
$R_{11} = 59.6$ [ $\Omega$ ]	$R_{c11} = 62.2$ [ $\Omega$ ]	$R_{e21} = 64.6$ [ $\Omega$ ]
$R_{12} = 59$ [ $\Omega$ ]	$R_{c12} = 62.5$ [ $\Omega$ ]	$R_{e22} = 65.2$ [ $\Omega$ ]
$R_{13} = 59.5$ [ $\Omega$ ]	$R_{c13} = 63$ [ $\Omega$ ]	$R_{e23} = 64.7$ [ $\Omega$ ]
	$C_{1c13} = 37$ [ $\mu$ F]	$C_{1e21} = 9.9$ [ $\mu$ F]
	$C_{2c13} = 32.6$ [ $\mu$ F]	$C_{2e22} = 10$ [ $\mu$ F]
		$C_{3e23} = 9.9$ [ $\mu$ F]

Detailed parameters of component elements – Table 1:

- for the electrical line:  $L_{11}$  – inductance 1, phase 1 of the electrical line;  $L_{12}$  – inductance 2, phase 2 of the electrical line;  $L_{13}$  – inductance 3, phase 3 of the electrical line;  $R_{11}$  – resistance 1, phase 1 of the electrical line;  $R_{12}$  – resistance 2, phase 2 of the electrical line;  $R_{13}$  – resistance 3, phase 3 of the electrical line. The feeding symmetrical line-to-neutral voltages are of 142 V rms.

- for distorting consumer one:  $L_{c11}$  – inductance 1, phase 1 of distorting consumer 1;  $L_{c12}$  – inductance 2, phase 2 of distorting consumer 1;  $L_{c13}$  – inductance 3, phase 3 of distorting consumer 1;  $R_{c11}$  – resistance 1, phase 1 of distorting consumer 1;  $R_{c12}$  – resistance 2, phase 2 of distorting consumer 1;  $R_{c13}$  – resistance 3, phase 3 of distorting consumer 1;  $C_{1c13}$  – capacitor 1, phase 3 of distorting consumer 1;  $C_{2c13}$  – capacitor 2, phase 3 of distorting consumer 1;  $EN_1$  – nonlinear element 1;  $EN_2$  – nonlinear element 2.

- for balanced consumer two:  $L_{e21}$  – inductance 1, phase 1 of consumer 2;  $L_{e22}$  – inductance 2, phase 2 of consumer 2;  $L_{e23}$  – inductance 3, phase 3 of consumer 2;  $R_{e21}$  – resistance 1, phase 1 of consumer 2;  $R_{e22}$  – resistance 2, phase 2 of consumer 2;  $R_{e23}$  – resistance 3, phase 3 of consumer 2; capacitor 1, phase 1 of consumer 2;  $C_{2e22}$  – capacitor 2, phase 2 of consumer 2;  $C_{3e23}$  – capacitor 3, phase 3 of consumer 2.

In the case of nonlinear elements, which have the property of distorting and clipping waveform shapes, a distinct electrical schematic is presented in Fig. 2. These nonlinear elements introduce significant unbalances and distortions in the experimental circuits, affecting both the electrical parameters of the system and the quality of the signal in question. The waveform deformations inflicted by these components can lead to the generation of additional harmonics, which must be analyzed in detail to understand their impact on the entire circuit.

Furthermore, integrating computer-assisted simulations

provides valuable support for validating Țugulea's power theory, demonstrating its applicability in real electrical networks. This approach highlights the impact of nonlinearities on power balance within the network and potential optimization solutions to minimize distortions and their adverse effects in unbalanced networks with neutral.

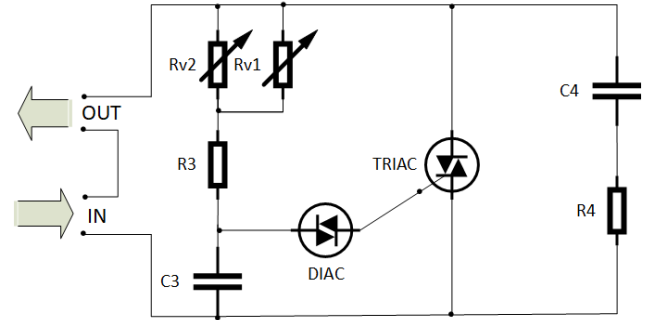

Fig. 2 – Detailed description of identical circuits  $EN_1$  and  $EN_2$ .

In Fig. 2 there are:  $R_{v1}$ ,  $R_{v2}$  – potentiometric resistors;  $R_3$ ,  $R_4$  – resistors;  $C_3 = 100$  nF,  $C_4 = 100$  nF – capacitors; DIAC: DB3 32V@2A; TRIAC: BTA16 600B Aislado 600 V@16A.

Table 2

Component values for  $EN_1$  and  $EN_2$ .

Component	$R_{v1}$ [k $\Omega$ ]	$R_{v2}$ [k $\Omega$ ]	$R_3$ [k $\Omega$ ]	$R_4$ [k $\Omega$ ]	$C_3$ [nF]	$C_4$ [nF]
Value	500	2000	4.7	0.1	100	100

For the two electrical charges (incandescent bulbs) from the charges of the nonlinear elements  $EN_1$  and  $EN_2$ . In the experiment, the voltage-current characteristics were determined and shown in Table 3 to evaluate their behavior under different operating conditions. These features were interpolated and implemented in the simulation program, allowing a more precise correlation between the experimental data and those obtained by numerical simulation.

Table 3

Voltage-current characteristic for the two incandescent bulbs, loads for  $EN$ .

		Incandescent bulb 1							
$U$ [V]		0	20	40	60	80	100	120	140
$I$ [A]	0	0.21	0.29	0.36	0.4	0.47	0.51	0.56	
		Incandescent bulb 2							
$U$ [V]		0	20	40	60	80	100	120	140
$I$ [A]	0	0.37	0.47	0.55	0.64	0.71	0.77	0.83	

By incorporating these features into the simulation environment, the goal is not only to improve the accuracy of the results but also to achieve a high level of consistency between theoretical analysis, practical measurements, and computer modeling. This process provides comprehensive validation of circuit behavior, contributing to a better understanding of the influence of nonlinearities and imbalances on the entire three-phase system with the neutral conductor.

### 3. NUMERICAL SIMULATION, RESULTS, AND DISCUSSIONS

The simulation results, analysis, and implementation output in the SPICE software for the circuit described in the previous chapter confirm verifying the balance of active and reactive, symmetry, non-symmetry, and residual powers (Table 4).

The powers result from software developed by the authors in [1, 2]. The voltage and current waveforms are decomposed in Fourier series (with 50 harmonics), and the symmetry, non-symmetry, and residual active and reactive powers are

computed for each consumer, including the power line. The calculation of the errors returns values below 1 %, which confirms the accuracy of the simulation, demonstrating, once again, the validity and consistency of the power theory. More importantly, it certifies the usefulness of the theory for assessing the effects of distortion and imbalance on the supply line and the consumers connected to it.

Table 4

Symmetry, non-symmetry, residual, and total active and reactive powers corresponding to circuit model one from [2]; power balance SPICE verification.

	$P_s$ [W]	$P_n$ [W]	$P_r$ [W]	$P_{total}$ [W]
Power line	70.6535	32.9351	7.8214	111.4099
Consumer 1	164.9760	-34.1963	-10.9799	119.7998
Consumer 2	21.0224	1.2635	3.1613	25.4473
Sum [var]	256.6519	0.0023	0.0028	256.6570
3 ~ source	256.8164			
Error [%]	0.0620	-0.0068	-0.0258	

	$Q_s$ [var]	$Q_n$ [var]	$Q_r$ [var]	$Q_{total}$ [var]
Power line	0.7744	0.3679	0.3938	1.5361
Consumer 1	28.6738	5.6340	2.3851	36.6929
Consumer 2	-102.6234	-6.0118	-2.7672	-111.4024
Sum [var]	-73.1753	-0.0098	0.0117	-73.1734
3 ~ source	-73.2198			
Error [%]	0.7744	0.1637	-0.4224	

The waveforms of the currents and voltages below are obtained by running the SPICE simulation program for the electrical circuit, which has the parameters shown in Tables 1 and 2 as input quantities measured in the laboratory on the experimental circuit.

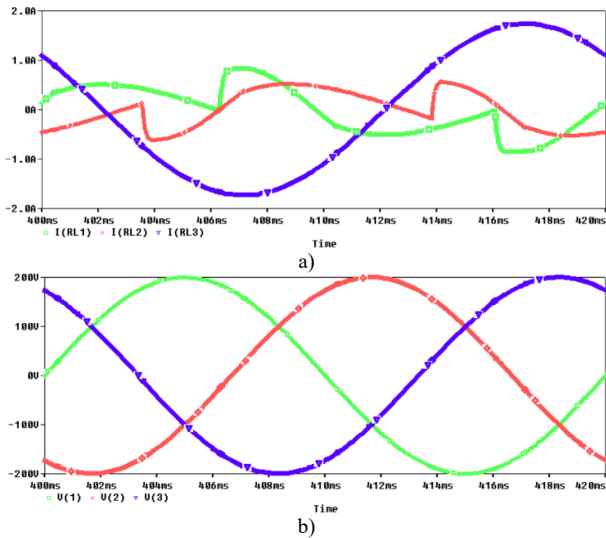

Fig. 3 – a) the waveforms of the three-phase system of currents corresponding to the three phases of the supply line; b) the waveforms of the three-phase, symmetrical supply voltage system of direct succession.

It is easy to see that consumer one is distorting, worsening the quality of the power delivered to consumer 2. Even though the supply voltage system is sinusoidal and symmetrical (positive sequence only), the voltage system at the consumers' terminals becomes non-symmetrical and non-sinusoidal. The phase current systems, both for the supply line and the nonlinear and unbalanced consumer 1 and the linear and balanced consumer 2, are all non-symmetrical and non-sinusoidal.

Comparing the results obtained by acquiring experimental data from the actual circuit and the software simulations, we noticed an influence due to measurement, data acquisition, and circuit modeling errors. These errors affect numerical values

and waveforms, but the results are visible and consistent.

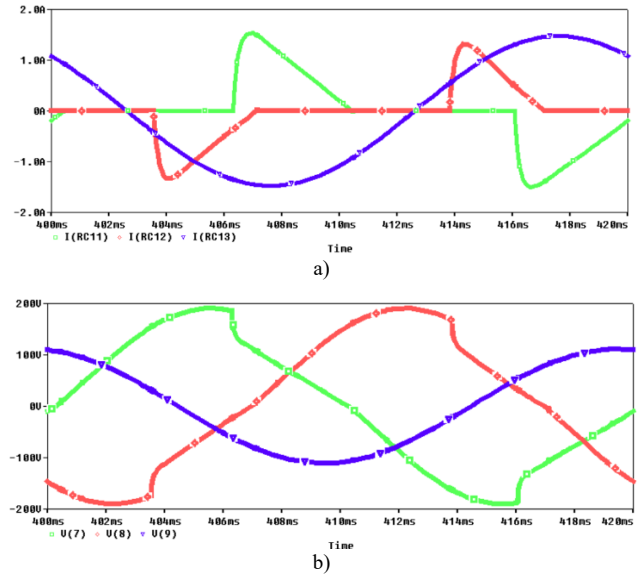

Fig. 4 – a) the waveforms of the currents corresponding to the three phases of the distorting consumer 1; b) the waveforms of the voltages at the terminals of the distorting consumer 1.

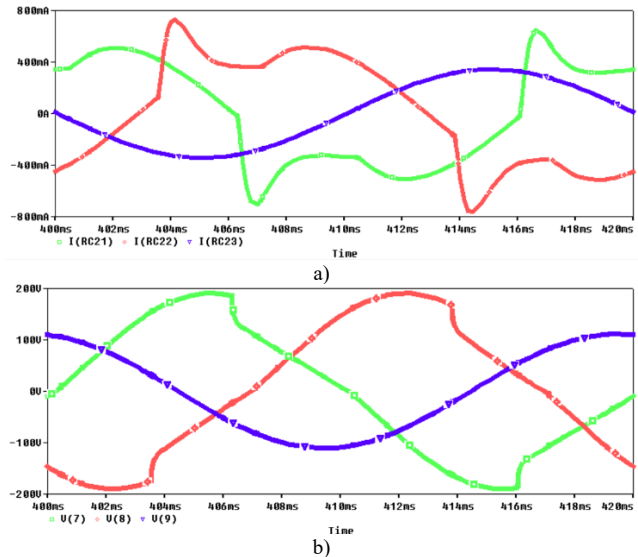

Fig. 5 – a) the waveforms of the currents corresponding to the three phases of the balanced consumer 2; b) the waveforms of the voltages at the terminals of the balanced consumer 2.

The comparison between the data obtained through the experiment and those obtained through software simulation allows the identification of the general trends. It highlights the particularities that cannot always be captured through a strictly analytical approach. Therefore, the interpretation of the results is not only based on raw data but requires careful analysis and critical evaluation, emphasizing the importance of the correlation between the experiment and the simulation.

#### 4. CONCLUSIONS

The results obtained in this paper, provided by the software simulation, are consistent with those obtained due to the data acquisition through measurements made on a type of electrical circuit with a similar configuration described in the previous article [2].

The results obtained both experimentally and through software simulations confirm the validity of the Țugulea power theory. The analysis of the data resulting from the

SPICE simulation showed that, regardless of the type and level of disturbances present in the system, the power balance was verified, thus demonstrating the consistency of the applied theoretical principles.

Moreover, apparent correlations were observed between the measured values and those obtained by software simulation, thus strengthening the credibility of the theory implementation, both in simulated and experimental conditions. Using a specialized simulation environment confirmed the experimental results and extended the analysis by exploring additional scenarios that would not be easy to reproduce in actual operating conditions.

Thus, both the experimental approach and the numerical modeling demonstrate that the theory of symmetry, non-symmetry, and residual powers (defined by the Țugulea power theory) provides a valid and applicable framework for the analysis and interpretation of power phenomena in complex electrical networks, in the presence of nonlinear circuit elements, providing a solid method for quantifying losses and identifying sources of disturbance, making it easier to diagnose and solve problems in power grids.

In conclusion, the research emphasizes the need to implement advanced tools for measuring and managing the circulation of energies corresponding to the powers introduced by the discussed theory. These tools must accurately quantify the influences of nonlinearities and imbalances in power grids. Developing detailed diagrams of such circulations would be essential to optimizing complex networks, ensuring more efficient and sustainable energy management.

The theoretical and practical verification of the symmetric component power theory (SCPT) paves the way for the correct measurement and fair billing of active and reactive energies at the terminals of three-phase consumers, indicating the actual direction of the power transfer corresponding to the elements of the energy storage circuit, and the components associated with the imbalances and non-linearities of the consumers in the electrical network, which can be recorded and billed independently.

#### ACKNOWLEDGMENTS

The authors warmly thank Prof. Alexandru M. Morega for his advice. This work was financially supported by grant GNAC ARUT no. 28/9.10.2023, ID 220235135 – National Program for Research of the National Association of Technical Universities, entitled “Experimental platform for the determination of unbalance and residual powers in three-phase networks – TRICODD”.

Received on 11 March 2025

#### CREDIT AUTHORSHIP CONTRIBUTION STATEMENT

Ionuț-Marius Mindreanu: formal analysis, literature investigation, data organization, writing – original manuscript preparation.

Radu-Mircea Ciuceanu: modeling methodology, simulation platform design, data consistency analysis and verification.

Iosif Vasile Nemoianu: conceptualization, software development, writing – manuscript review and editing, funding, and procurement.

#### REFERENCES

1. I.M. Mindreanu, R.M. Ciuceanu, I.V. Nemoianu, *Experimental assessment of consumer unbalance and nonlinearity effects in*

- three-phase networks without neutral conductor*, Roum. Sci. Techn. – Électrotechn. et Énerg., **69**, 3, pp. 287–292 (2024).
2. I.M. Mindreanu, R.M. Ciuceanu, I.V. Nemoianu, *Demonstrating the symmetry and non-symmetry components balance in grids with neutral conductor*, Roum. Sci. Techn. – Électrotechn. et Énerg., **69**, 4, pp. 413–418 (2024).
3. I.M. Mindreanu, A.M. Morega, *Monitoring power flow in end-user consumption systems*, 13<sup>th</sup> International Symposium on Advanced Topics in Electrical Engineering (ATEE) (2023).
4. R. Thankakan, E.-R.-S. Nadar, *A novel DC-DC converter fed by PV source employing improved incremental conductance algorithm under partial shadow conditions*, Rev. Roum. Sci. Techn.–Électrotechn. et Énerg., **67**, 2, pp. 145–150 (2022).
5. K. Benmouiza, *Nonlinear clustered adaptive-network-based fuzzy inference system model for hourly solar irradiation estimation*, Rev. Roum. Sci. Techn.–Électrotechn. et Énerg., **68**, 1, pp. 7–11 (2023).
6. K. Guerraiche, F. Midouni, N.El. Sahrtaoui, L. Dekhici, *Impact de la génération distribuée sur la coordination des relais directionnels (Impact of distributed generation on the coordination of directional relays)*, U.P.B. Sci. Bull., Series C, **85**, 1, pp. 275–290 (2023).
7. F. Amrane, A. Chaiba, B. François, *Improved adaptive nonlinear control for variable speed wind-turbine fed by direct matrix converter*, Rev. Roum. Sci. Techn.–Électrotechn. et Énerg., **68**, 1, pp. 58–64 (2023).
8. S. Ye, F. Xu, M. Lin, Y. Li, *Optimal scheduling of integrated energy systems based on mixed integer linear programming with flexible load accounting*, U.P.B. Sci. Bull., Series C, **85**, 2, pp. 331–348 (2023).
9. G. Shahgholian, S.M.A. Zanjani, *A study of voltage sag in distribution system and evaluation of the effect of wind farm equipped with doubly-fed induction generator*, Rev. Roum. Sci. Techn.–Électrotechn. et Énerg., **68**, 3, pp. 271–276 (2023).
10. Y. Benyssaad, *Nouveau modèle d'optimisation basé sur la 'maintenance axée sur la fiabilité' des réseaux de distribution électrique (A new optimization model based on 'reliability centered maintenance' of electrical distribution network)*, Rev. Roum. Sci. Techn.–Électrotechn. et Énerg., **67**, 1, pp. 27–32 (2022).
11. J. Chen, K. Liu, L. Du, *Dynamic error analysis of smart electricity meter under complex fluctuating load*, U.P.B. Sci. Bull., Series C, **85**, 3, pp. 433–445 (2023).
12. N. Zidane, S. Lalouni Belaid, *A new fuzzy logic solution for energy management of hybrid photovoltaic/battery/hydrogen system*, Rev. Roum. Sci. Techn.–Électrotechn. et Énerg., **67**, 1, pp. 21–26 (2022).
13. A. Abbadi, F. Hamidia, Y. Chiba, *Adaptive non-linear voltage controller based multivariable sliding mode extremum seeking approach applied to multi-machine power system*, Rev. Roum. Sci. Techn.–Électrotechn. et Énerg., **67**, 1, pp. 65–72 (2022).
14. A. Țugulea, *Considerations on the energy effects of distorting regimes (in Romanian)*, Energetica, **XXXIV**, 1, pp. 27–31 (1986).
15. A. Țugulea, *Considerations regarding energy effects in the non-symmetrical harmonic regimes of three-phase networks (in Romanian)*, Energetica, **XXXIV**, 3, pp. 121–130 (1986).
16. A. Țugulea, C. Golovanov, *The energy effects of non-symmetrical and distorting regimes of electric power systems. Measurement possibilities*, ENER, **3**, pp. 130–159, 1987.
17. A. Țugulea, *Power flows under non-sinusoidal and non-symmetric periodic and almost periodic steady states of electrical power system*, Proc. of 6<sup>th</sup> Int. Conf. On Harmonics in Power Systems (ICHPS VI), Bologna, Italy, pp. 388–395 (1994).
18. A. Țugulea, *Criteria for the definition of the electric power quality and its measurement systems*, European Transactions on Electrical Power, **6**, 5, pp. 357–363 (1996).
19. R.M. Ciuceanu, I.V. Nemoianu, V. Mănescu (Păltănea), G. Păltănea, *On professor Țugulea's visionary power theory: a review, recent advances and perspectives*, Roum. Sci. Techn. – Électrotechn. et Énerg., **63**, 2, pp. 123–127 (2018).
20. I.V. Nemoianu, R.M. Ciuceanu, *Non-symmetry and residual active and reactive powers flow in non-linear three-phase unbalanced circuits*, Roum. Sci. Techn. – Électrotechn. et Énerg., **60**, 2, pp. 227–237 (2015).
21. I.V. Nemoianu, R. M. Ciuceanu, *Characterization of non-linear three-phase unbalanced circuits powers flow supplied with symmetrical voltages*, Roum. Sci. Techn. – Électrotechn. et Énerg., **60**, 3, pp. 355–365 (2015).
22. B.D.H. Tellegen, *A General Network Theorem, with Applications*, Philips Res. Rep., **7**, pp. 259–269 (1952).